



CONTROL PANEL

“B” Model Aerobic Control Panel

Features & Benefits

- Circuit Breakers for Pump, Compressor & Alarm Circuits
- Large & Easy to Access Terminal Block
- Externally Mounted Run/Mute/Test Switch w/UV resistant sealing boot
- Externally Mounted Audible Alarms
- Rugged UV resistant Externally Mounted Alarm Lights
- Separate Air Loss Alarm Circuit
- Externally or Internally Mounted Air Pressure Switch
- Durable Weather Resistant Hinged Poly Enclosure
- Silk Screen Back Panel
- Ground Lug
- Easily Replaceable Components
- Nema 4x Rating
- Color Coded Internal Wiring
- Built and Labeled to UL 508A Standard
- Works with most Aerobic Treatment Systems
- Provided with Wiring Schematic and Detailed Connection Diagram for Installer
- Mounting Feet for Enclosure

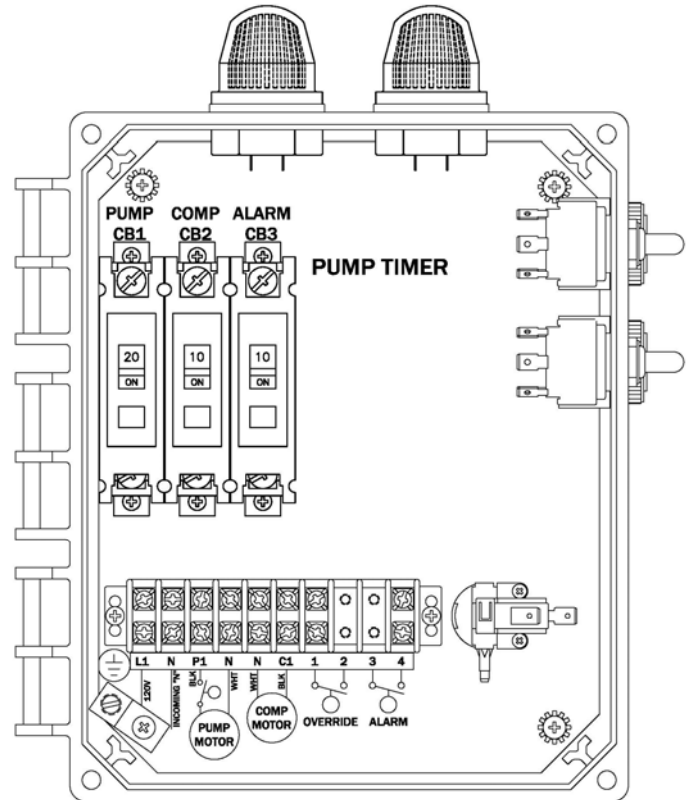

(50B006-BIO-B Shown)

Available Options

- Externally Mounted Pump Test Switch
- Auto-Dialer
- Locking Stainless Steel Latch
- 24 Hr Timer (See 50B005-BIO-A)
- Mercury or Mechanical Float Switches for the Pump and High Water Alarm Circuits



“A” Model Aerobic Control Panel

Panel Dimensions

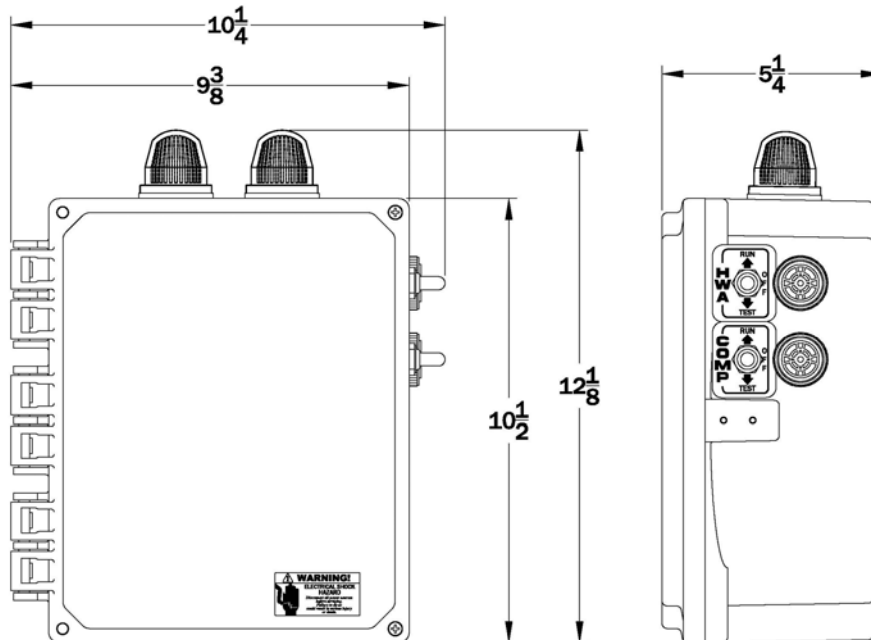

Wiring Schematic

