

Pump Specification

406-Series Automatic Drain Pump

Models

406

406HV

406HVK

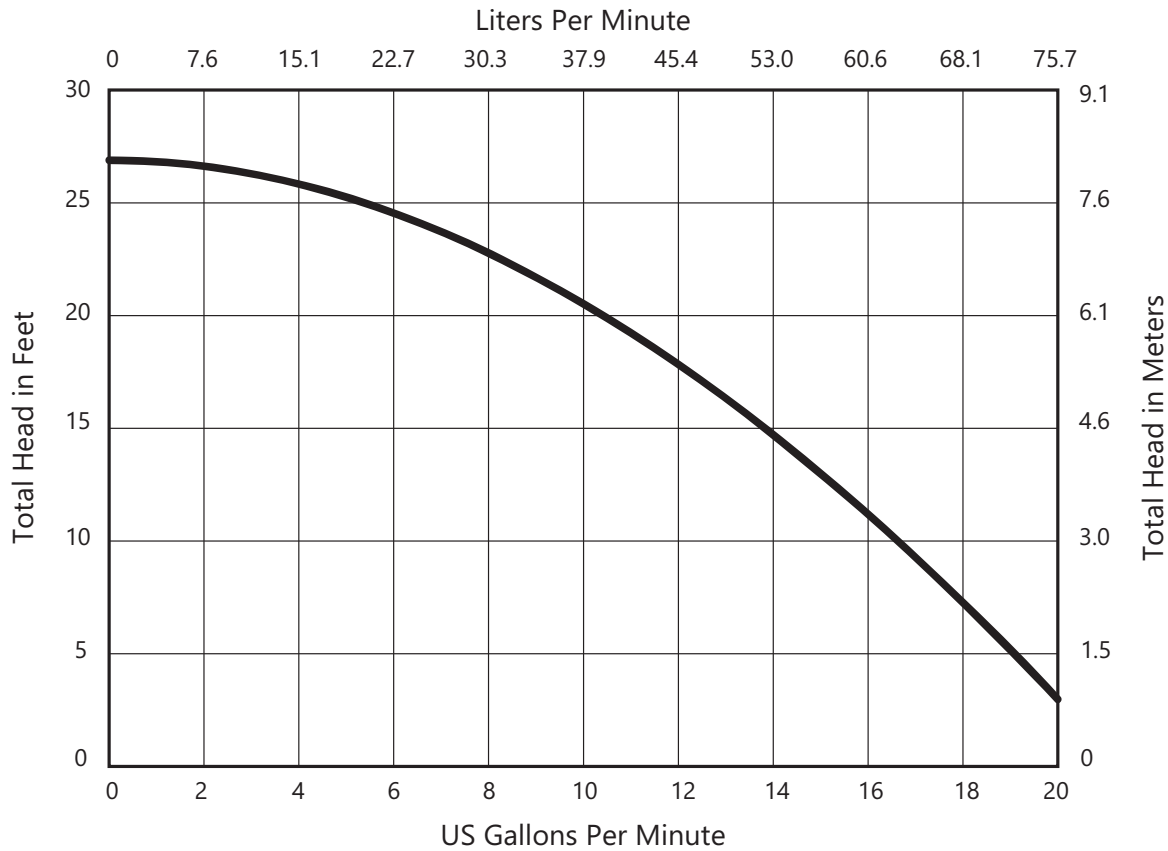
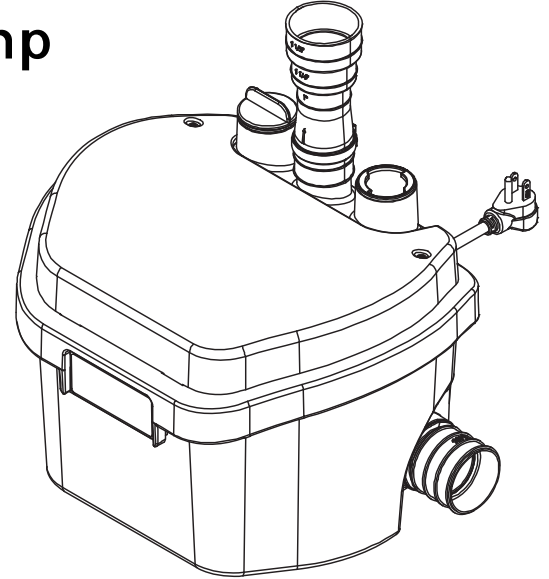

For proper performance, tank inflow cannot exceed pump discharge capacity at the installed head level.

406-Series Dimensional Data

NOTE: NEMA 5-15P
PLUG SHOWN

PROPRIETARY AND CONFIDENTIAL

THE INFORMATION CONTAINED IN THIS DRAWING IS THE SOLE PROPERTY OF LIBERTY PUMPS INC. ANY REPRODUCTION IN PART OR AS A WHOLE WITHOUT THE WRITTEN PERMISSION OF LIBERTY PUMPS INC. IS PROHIBITED.

APPLICATION

DO NOT SCALE DRAWING

406 SERIES

DWG. NO.

SIZE B	REV. A
SCALE:1:4	WEIGHT: LBS
SHEET 1 OF 1	

Model 406 Dimensional Data

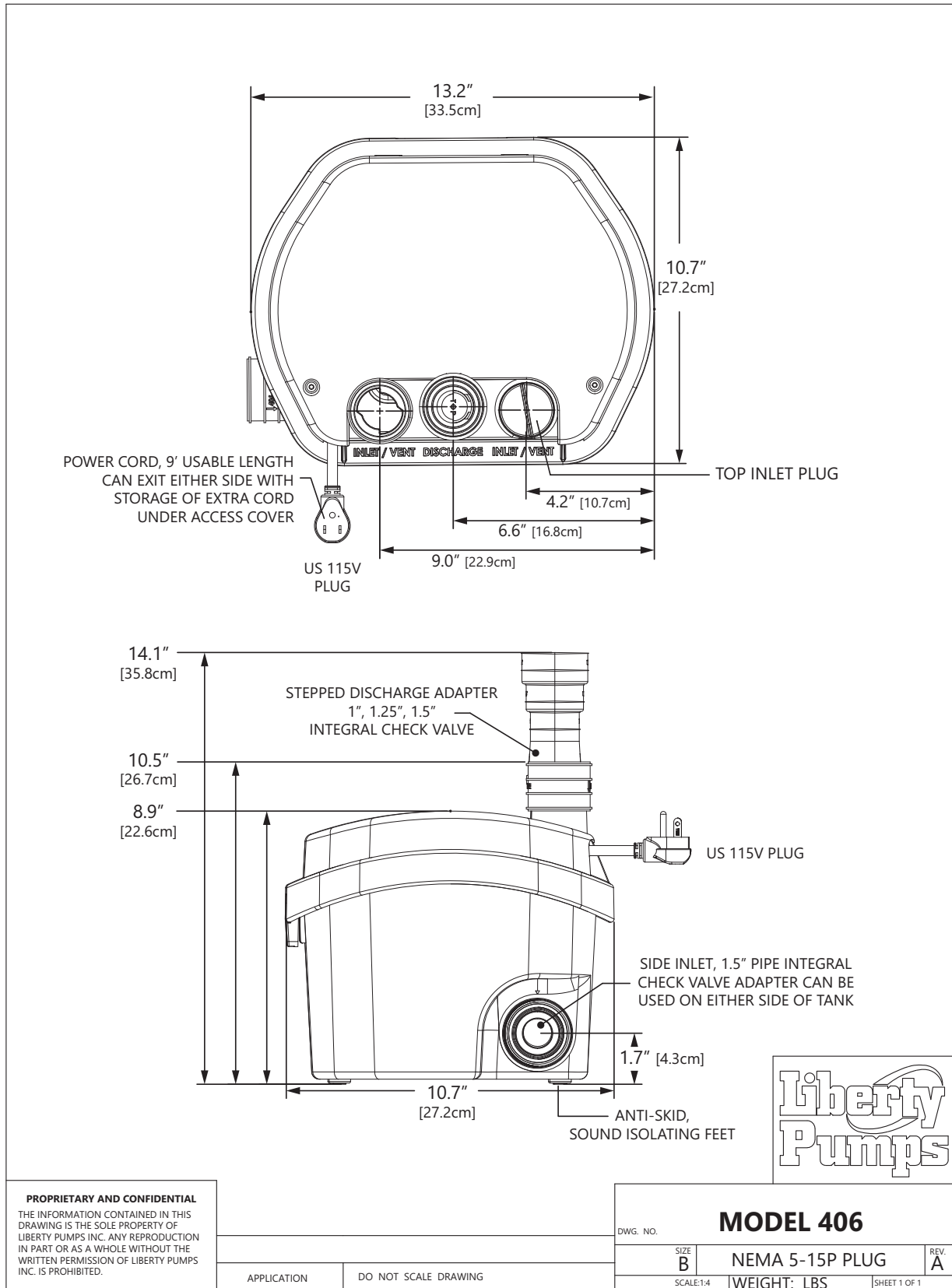

Model 406HV Dimensional Data

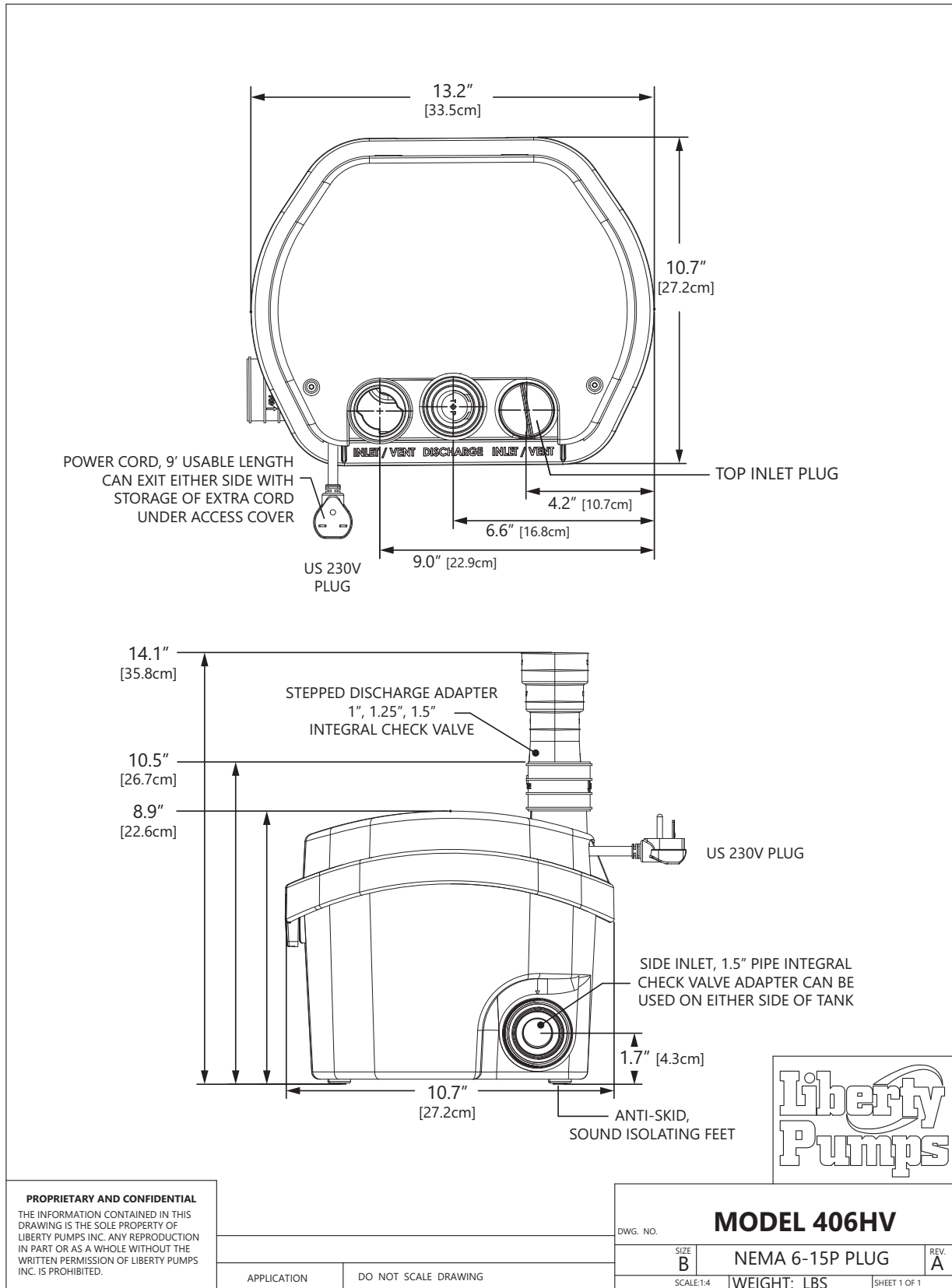

Model 406HVK Dimensional Data

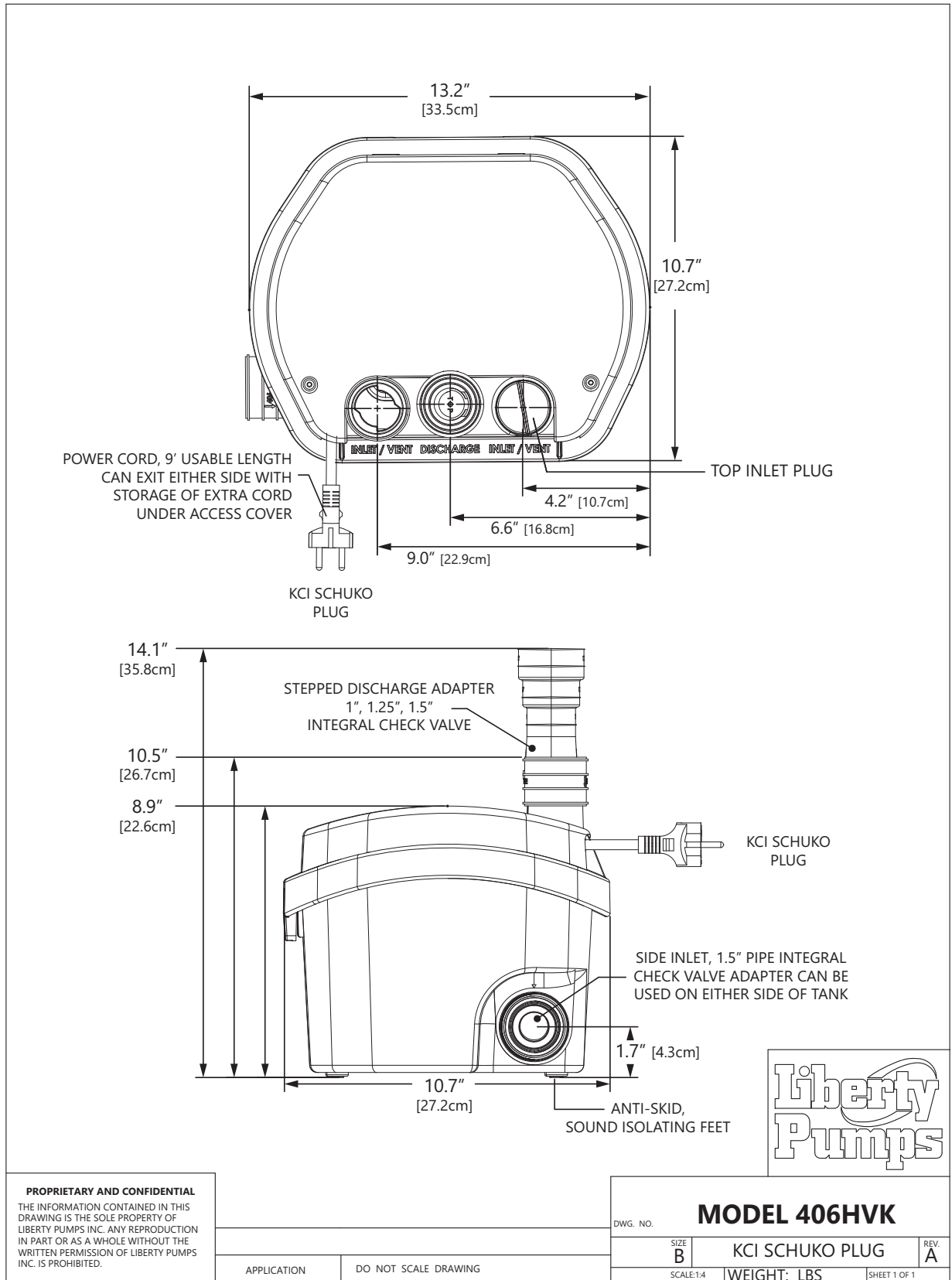

406-Series Electrical Data

MODEL	HP	VOLTAGE	PHASE	HZ	FULL LOAD AMPS	LOCKED ROTOR AMPS	THERMAL OVERLOAD TEMP	STATOR WINDING CLASS	CORD LENGTH (FT)	DISCHARGE (IN)	AUTOMATIC
406	1/6	115	1	60	1.7	4.7	120°C	B	9	1, 1-1/4,1-1/2	YES
406HV	1/6	200/230	1	60	1.0	2.5	120°C	B	9	1, 1-1/4,1-1/2	YES
406HVK	1/6	220	1	60	1.0	2.5	120°C	B	9	1, 1-1/4,1-1/2	YES

406-Series Technical Data

PUMP TYPE	APPLIANCE GRADE DRAIN PUMP
INLET SIZE	3 x 1-1/2"
VENT SIZE	1-1/2"
DISCHARGE PIPE DIAMETER	1", 1.25", 1.5" WITH INTEGRAL CHECK VALVE
DISCHARGE RATE @ 17 FT	12 GPM [45.4 LPM]
MAX TOTAL DYNAMIC HEAD	27 FT [8.2 METERS] FOR PROPER PERFORMANCE, TANK INFLOW CANNOT EXCEED PUMP DISCHARGE CAPACITY AT THE INSTALLED HEAD LEVEL.
CAPACITY	1.91 GALLONS [7.6 LITERS]
INLETS	TOP: x1 SIDE: x2 PROVISIONS FOR ONE SIDE INLET CHECK VALVE INCLUDED, CAN BE USED ON EITHER SIDE INLET LOCATION
CONNECTIONS	DIRECT: SINK, SHOWER, LAUNDRY SINK, BAR SINK
	INDIRECT: WASHING MACHINE, DISHWASHER
IMPELLER	MULTI-VANE SEMI-OPEN
SOLIDS HANDLING	1/8"
PAINT (PUMP)	ELECTROPLATED MOTOR PLATE, REMAINDER PLASTIC
MAX LIQUID TEMP	140°F [60°C]
THERMAL OVERLOAD	248°F [120°C]
MOTOR HOUSING	ABS
VOLUTE	ENGINEERED POLYMER
SHAFT	STAINLESS
HARDWARE	STAINLESS
O-RINGS	BUNA-N
SHAFT SEAL	DUAL SEAL (LIP & MECHANICAL)
TANK MATERIAL	ABS
NOISE LEVEL	68 DB
WEIGHT	13.5 LBS / 6.1 KG
CERTIFICATIONS: Models 406, 406HV	cCSAus (ASME A112.3.4-2018, CSA B45.9-18), SSPMA

406-Series Specifications

1.01 GENERAL

The contractor shall provide labor, material, equipment, and incidentals required to provide _____ (QTY) appliance grade drain pumps as specified herein. The pump models covered in this specification are 406-Series drain pumps. The pump furnished for this application shall be model _____ as manufactured by Liberty Pumps.

2.01 OPERATING CONDITIONS

Each drain pump shall be rated at 1/6 hp, _____ volts, 60 Hz, 3450 RPM. The unit shall produce _____ GPM at _____ feet of total dynamic head.

The drain pump shall be capable of handling effluent with 1/8" solid handling capability. The drain pump shall have a max total dynamic head of 12 GPM @ 27 feet.

3.01 CONSTRUCTION

Each drain pump shall be equal to the  Certified¹ 406-Series as manufactured by Liberty Pumps, Bergen NY. The motor housing shall be constructed of ABS. All mating parts shall be sealed with a Buna-N O-ring or engineered gasket. All fasteners shall be stainless steel. The motor and switch shall be protected on the top side with an ABS access cover. The motor shall be protected on the lower side with both an engineered lip seal and two-piece carbon ceramic mechanical seal with stainless steel springs. The tank shall be made of ABS.

4.01 ELECTRICAL POWER CORD

The drain pump shall be supplied with 9 feet of multi-conductor power cord. The power cord shall be sized for the rated full load amps of the pump in accordance with the National Electric Code.

5.01 MOTORS

All motors shall be air filled and class B insulated NEMA B design, rated for continuous duty. At maximum load the winding temperature shall not exceed 130°C unsubmerged. The pump motor shall have an integral thermal overload switch in the windings for protecting the motor. The capacitor circuit shall be mounted internally in the pump.

6.01 BEARINGS AND SHAFT

Upper and lower ball bearings shall be required. The bearings shall be a single ball/race type bearing. Both bearings shall be permanently lubricated by grease. The motor shaft shall be made of stainless steel and have a minimum diameter of 0.175".

7.01 SEALS

The pump shall have an engineered lip seal with stainless steel springs and a secondary mechanical carbon ceramic seal. The motor plate/housing interface shall be sealed with a Buna-N O-ring.

8.01 IMPELLER

The impeller shall be molded engineered polymer. It shall be threaded to the motor shaft.

¹ Model 406HVK is not  Certified.

9.01 CONTROLS

All units are supplied with a CSA and UL approved automatic vertical float switch. The switch shall be mounted under the access cover and accessible for easy serviceability.

10.01 SUPPORT

The ABS tank shall be a freestanding unit.

11.01 SERVICEABILITY

Components required for the repair of the pump shall be shipped within a period of 24 hours.

12.01 TESTING

The pump shall have a ground continuity check and the motor chamber shall be hi-potted to test for electrical integrity, moisture content and insulation defects. The tank shall be pressurized, and an air leak decay test performed to ensure integrity of the tank seal. The pump shall be run, voltage current monitored, and checked for noise or other malfunction.

13.01 QUALITY CONTROL

The pump shall be manufactured in an ISO 9001 certified facility.

14.01 WARRANTY

Standard limited warranty shall be 3 years.