



# CONTROL PANEL

## “50A509” Model Duplex 3 Phase Control Panel

### Features & Benefits

- Circuit Breakers for Pumps
- IEC Motor Contactors & Overloads
- Easy to Access Terminal Block
- Usable with 208 VAC or 230VAC
- Externally Mounted Test/Normal/Silence Switch  
w/UV resistant sealing boot
- Externally Mounted Audible Alarm
- Pump Hand-Off-Auto Switches
- Pump Running Lights
- Transformer w/Primary & Secondary Fuse Protection
- Large External Alarm Light
- Dead Front Inner Door
- Separate Control & Alarm Fuses
- Alternating Relay w/Selector Switch
- Ground Lugs
- Color Coded Internal Wiring
- Rugged Weather Resistant Hinged Poly Enclosure w/Sst Latches
- Built and Labeled to UL 508A Standard w/Nema 4x Rating
- Provided with Wiring Schematic and Detailed Connection Diagram for Installer
- Mounting Feet for Enclosure

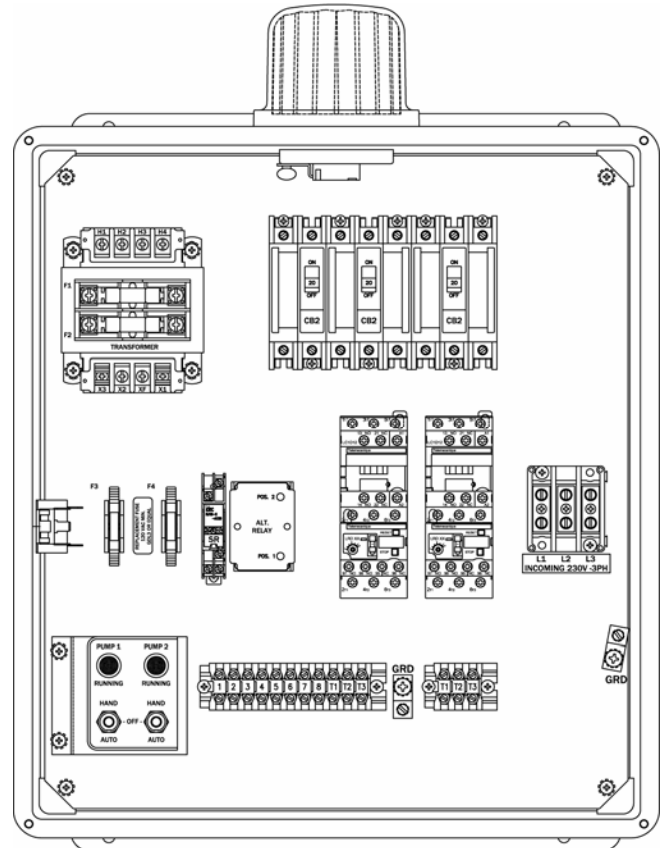

(Standard 50A509 Model Shown)

### Available Options(\*)

- Fiberglass Enclosure
- Flasher
- Mercury or Mechanical Float Switches for the Pumps and High Water Alarm Circuits



\*Note: Consult the factory for other available options. Also some options may require an increase in the enclosure size.

**“50A509” Model Duplex 3 Phase Control Panel**

**Panel Dimensions**

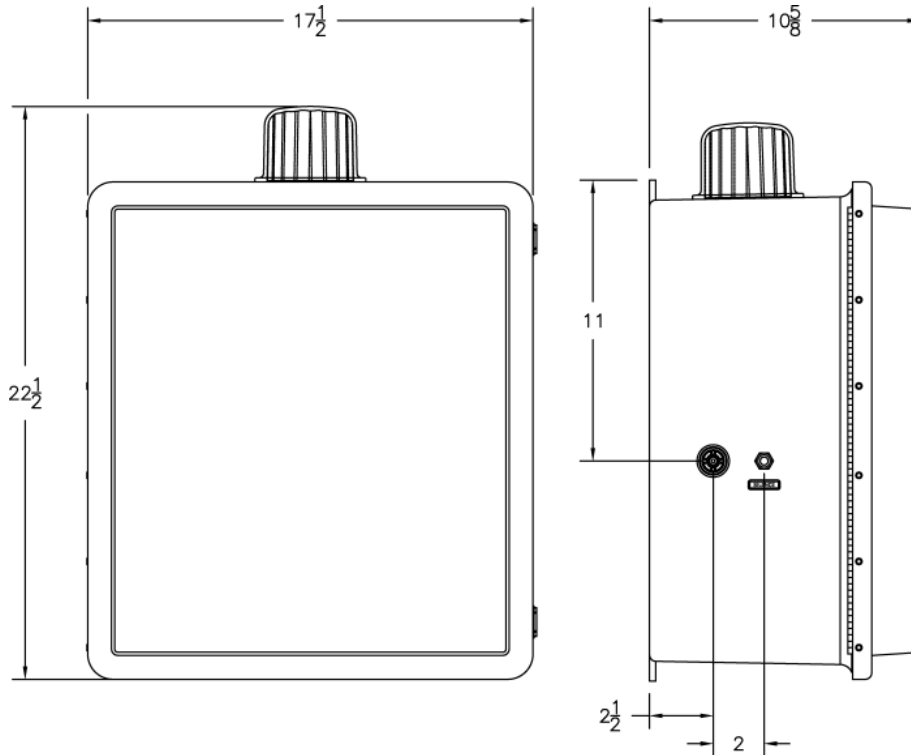

**Panel Schematic**

POWER CIRCUIT (3 WIRE SERVICE)  
230V - 3PH - 60Hz

